

ARCHAEOLOGICAL EXCAVATIONS IN TWO BURIAL MOUNDS AT 'ATELE, TONGATAPU

JANET M. DAVIDSON
Auckland Institute and Museum

Abstract. Excavations in two earthen mounds are described. The structure of the two mounds and the method of interment within them are similar in spite of a noticeable difference in size. Both mounds were used over a period of time. Some evidence for earlier use of both sites for purposes other than burial was found. The status of burial mounds as field monuments in Tonga and their significance in Tongan prehistory are discussed.

The fieldwork described in this paper took place on Tongatapu from July to September 1964. The research was part of the Polynesian Prehistory Programme financed by the National Science Foundation of the United States and sponsored by the Bernice P. Bishop Museum, Honolulu (Emory 1962).

Tonga was not included in the fieldwork proposals of the original programme. However, a reallocation of funds was made to allow one archaeologist to spend a short time in Tonga, working in conjunction with a graduate student from the Australian National University, Mr. Jens Poulsen, who was already engaged in a twelve-month fieldwork programme there.

Poulsen had been in Tonga since September 1963 and was approaching the end of his fieldwork period. He had concentrated on shell midden sites, assembling a large collection of pottery and other artifacts and a certain amount of structural information (Poulsen 1967, 1968). While I could have excavated a similar site or sites, it seemed more useful to investigate quite different sites that would provide information about other activities in the past, but which might still yield some pottery by which they could be related to a general pottery sequence.

The importance of burial mounds of various kinds as field monuments in Tonga had been emphasized by more than one previous fieldworker (McKern 1929, Golson 1957). It is normally impossible to obtain permission to excavate such sites, however, and McKern's limited excavations had revealed relatively little information about them. In 1964, attention had been drawn to a number of small mounds, thought to be burial mounds, in the grounds of Tonga College at 'Atele, by Harold Hopkins, a former headmaster of the college. Many of these mounds exhibited characteristic traces of white sand, thought to be evidence of burial, and human bones had been recovered from one of them during gardening in the college plantations.

The mounds are typical of countless others throughout Tongatapu, but offered the great advantage of being traditionally unknown. Neither the Honourable Ve'ehala, Keeper of the Palace Records, nor the people of the surrounding towns knew who was buried in them. For this reason it was possible to obtain permission to excavate in the mounds. I decided, therefore, to survey all visible mounds in the college grounds, and then to excavate at least one, and preferably two mounds, to test the assumption that white sand was indicative of burial, and to discover the structure of the mounds and the nature of the interments, if such proved to exist. It was not anticipated that permission to remove skeletal material from Tonga would be granted, and the excavations were planned on the assumption that all remains would be reburied. After the excavation had been completed, permission to remove remains for further study was received.

Eight weeks were spent on the excavation, and a further week was spent on refilling the trenches and packing material for shipment to New Zealand. I employed an interpreter who was capable of assisting with plans and section drawings, and four labourers who proved exceptionally good, even among Polynesians, who often show an aptitude for archaeological work.

ACKNOWLEDGEMENTS I should like to record my thanks to the Government of Tonga for permission to excavate, and to remove skeletal material to New Zealand for study. I should also like to thank Dr. K. P. Emory, of Bishop Museum, Hawaii, for initiating my visit to Tonga.

My work was greatly facilitated by the presence of an archaeologist already familiar with the local scene. I am deeply indebted to Mr. Poulsen and his wife Meike, who made a number of arrangements for me and were of assistance in innumerable ways. Mr. Jack Golson paid a brief visit to Tonga while I was there and provided stimulating advice on the interpretation of stratigraphy in site To-At-2.

At Tonga College, I should like to thank Mr. L. Lancaster, Acting Principal during the first part of my visit, for permission to excavate in the college grounds; the staff and pupils for kindly tolerating the disturbance in their midst; and, above all, Mr. J. Chambers, later Acting Principal, and his wife Lyn, for their wonderful hospitality and help.

To my crew, Sione, Siaki, Mesi, Salise and, above all, my interpreter, David Niumeitolu, I must say *Malo 'aupito* for their work.

The value of the excavation is greatly enhanced by competent specialist study of the skeletal material obtained. I should like to take this opportunity of recording my appreciation of Mr. Pietrusewsky's work. I learned a lot about physical anthropology during his visit to Auckland.

Mr. K. Peters drew the illustrations for this report and Mr. C. Schollum printed the photographs.

SITE SURVEY AT 'ATELE

The grounds of Tonga College consist of about 220 acres lying to the south of the main road in the centre of Tongatapu, just beyond the townships of Pea and Ha'ateiho (Fig. 1). The area is thus situated near the

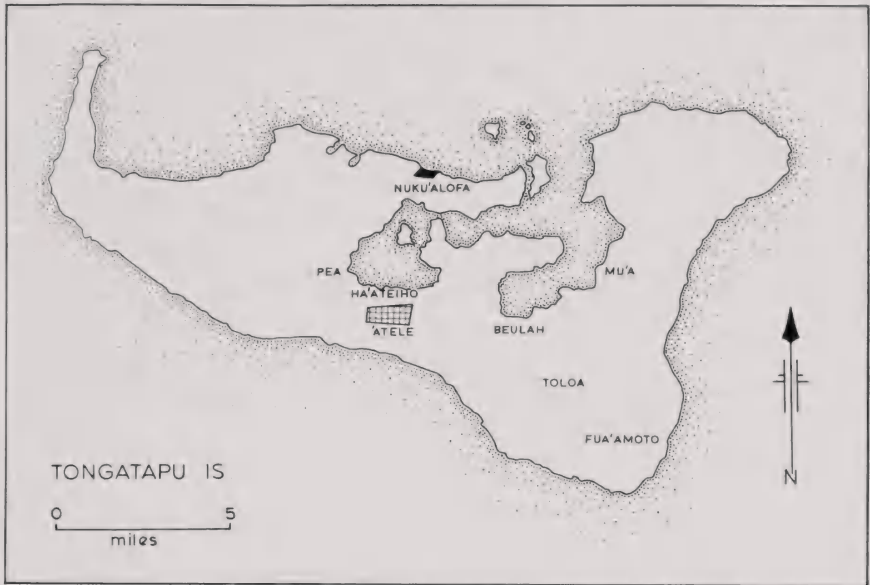

FIG. 1—Location of the 'Atele survey area on Tongatapu Island.

narrowest point of Tongatapu, a little over a mile from the raised southern cliffs, and less than half a mile from the edge of the shallow inner lagoon on the north side with its extensive shellfish beds. 'Atele is also close to the majority of pottery bearing midden sites excavated by Poulsen (1967, 1968), and a single site excavated more recently by Groube (personal communication).

The college grounds were thoroughly explored and all sites located were marked on an existing base map. Approximate diameters and heights were taken. The college is an agricultural training school, which grows its own food, and much of the total ground area is covered in crops of various kinds with some strips lying fallow. It is possible that some sites were not located in fallow strips, and also that some mounds have been destroyed in the area now occupied by playing fields, school buildings and teachers' houses. The existing mounds that were located are shown in Fig. 2. Mounds 14 to 17 were not exactly localised within the open pasture area. One of them is apparently a small burial mound, and the other three are very low mounds with no evidence of burial.

The mounds are of several types. There are three very large mounds in a group at the entrance to the college, one of which is still used for burials of members of a noble family. These mounds are named and their histories known; they far exceed in size any other site in the survey area.

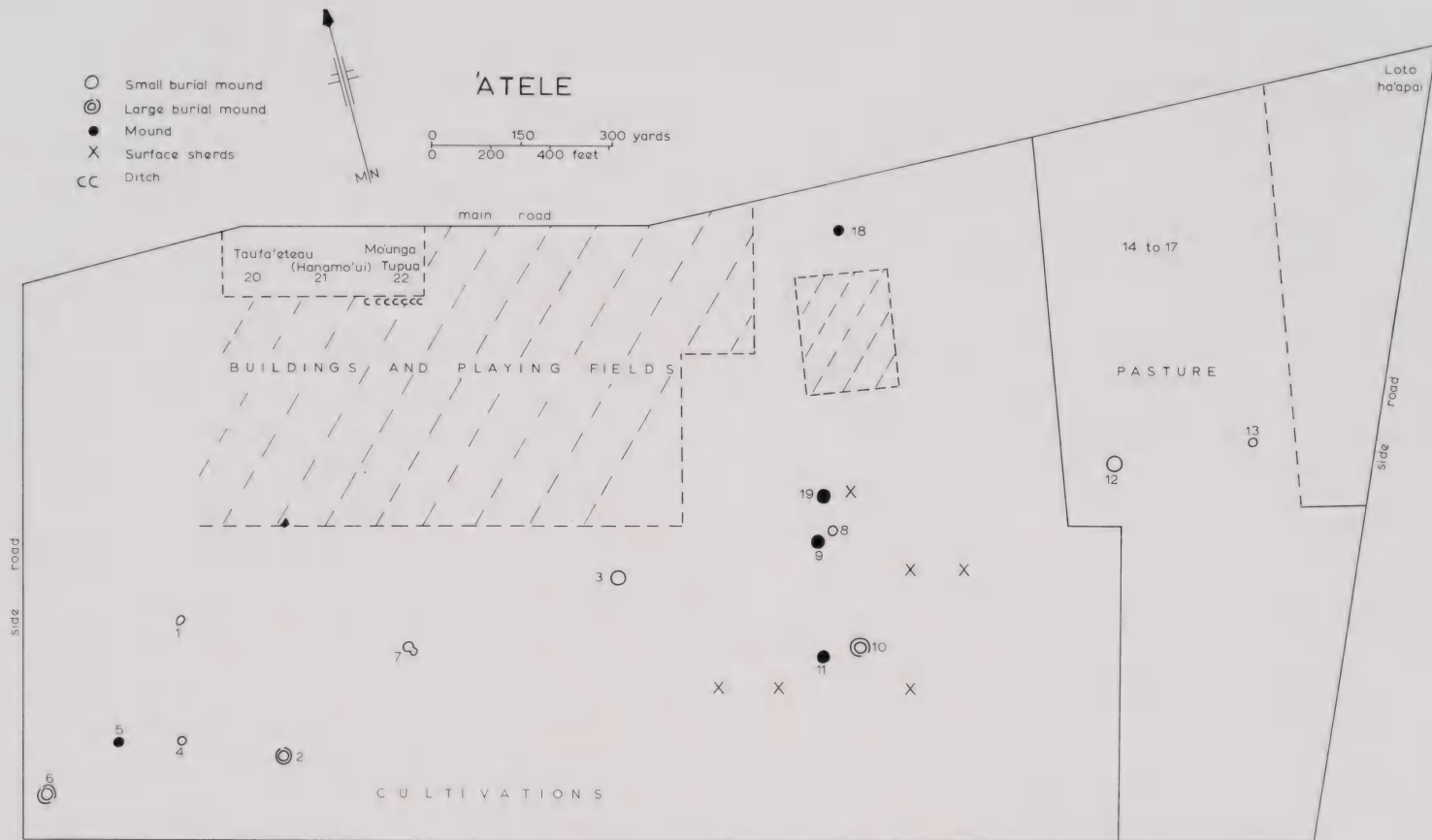

FIG. 2—Distribution of archaeological sites at 'Atele.

Apart from these, eleven other mounds were found which showed probable evidence of use for burial in the form of white coral sand scattered on the surface. These mounds seemed to fall into two definite groups according to size: eight small low mounds corresponded to McKern's description of *tanuanga* or commoners' burial places, and three larger mounds with definite traces of a surrounding ditch, seemed more like chiefs' burial mounds or *faitoka*, as described by McKern (1929, pp. 30-31).

In addition, eight very low mounds without surface evidence of burial, were located. Potsherds were found on or near several mounds. Several areas of the plantation also yielded a few sherds, although there was no visible trace of a mound in the vicinity. In general, the few potsherds from 'Atele were small and very weathered. There were no decorated sherds, and very few rim sherds. Much of the ground is well cultivated, offering fair conditions for the finding of sherds. It is therefore unlikely that a major pottery producing site exists in the college grounds unless it has been destroyed or covered over in the area of the school buildings and playing fields.

Apart from the three named mounds near the main road, there are no large mounds at 'Atele in terms of the size range observable in Tongatapu. This situation is in contrast to some areas where a number of large mounds, not known to be burial mounds, exist. In the grounds of both Tupou College and Beulah College, as well as in many of the townships, there are mounds much larger than those at 'Atele.

Two mounds were selected for excavation, one representative of each apparent size group. The sites were numbered according to a modified version of a system widely employed by archaeologists in Polynesia. To- is for the island and At- for the district where the sites are located.

To-At-1 is typical of the smaller burial mounds at 'Atele and To-At-2 of the larger ones. Although both are situated in the plantation areas, neither had apparently been ploughed. Ploughing in the adjacent field had extended to the edges of To-At-1, but had ceased at the edge of the ditch surrounding To-At-2.

EXCAVATIONS AT TO-AT-1

To-At-1 was the first site investigated. It is a small low mound, situated just behind the water tower at the college (Figs. 2-3). Because of its small size, I hoped that it would prove relatively simple, and provide a training ground for the excavators before tackling the larger mound.

The site is approximately 40 m in diameter, and its centre reaches a height of only 80 cm above the surrounding ground surface. A grid of two metre squares, separated by one metre baulks, was projected over the site. Excavation commenced in a two-metre square (D-4) whose south-east corner was situated at the approximate centre of the mound. Two other two-metre squares to the west and two half-squares to the north were excavated, and the intervening baulks removed. In this way, an estimated



FIG. 3—General view, To-At-1.

quarter of the central burial area was excavated and two long sections from the centre to the outside of the mound obtained. Finally, a trench five metres by one metre was excavated through the edge of the mound on the south side to check the presence of a surrounding ditch. Altogether, 27 square metres were excavated in this mound (Fig. 4).

Excavation was by hand trowel and brush, following natural layers. Burials were photographed and drawn in position before being removed.

STRATIGRAPHY

It was immediately apparent that the site had been used intensively as a burial place, with the result that the stratigraphy in the central portion of the mound consisted of a complicated series of intercutting burial pits which had largely destroyed the original layers. In the adjacent squares, however, five main layers could be identified, relating to four occupations or uses of the site. On the edges of the mound, ploughing had apparently disturbed any layers that had existed, producing a uniform brown garden soil similar to layer 5, sometimes with an admixture of blacker soil resembling layer 4. Numbering of layers was restricted to those areas of the mound where a full sequence of layers could be observed.

Stratigraphy from the base upwards was as follows (Fig. 5):

Layer 5.—A brown garden soil, similar to that in the surrounding fields, which overlay the clay subsoil. It filled several deep postholes.

Layer 4.—A thin layer of blackened soil, shell, burned coral oven stones and considerable charcoal. Several postholes were filled with this material, and one large firepit and one smaller one were cut from it into layer 5.

Layer 3.—A thin layer of mixed soil and white sand, which filled a few postholes. The earliest burials on the site were derived from this layer, and the burial pits were partially filled with similar material.

Layer 2.—Sterile clay and soil used on the construction of the mound.

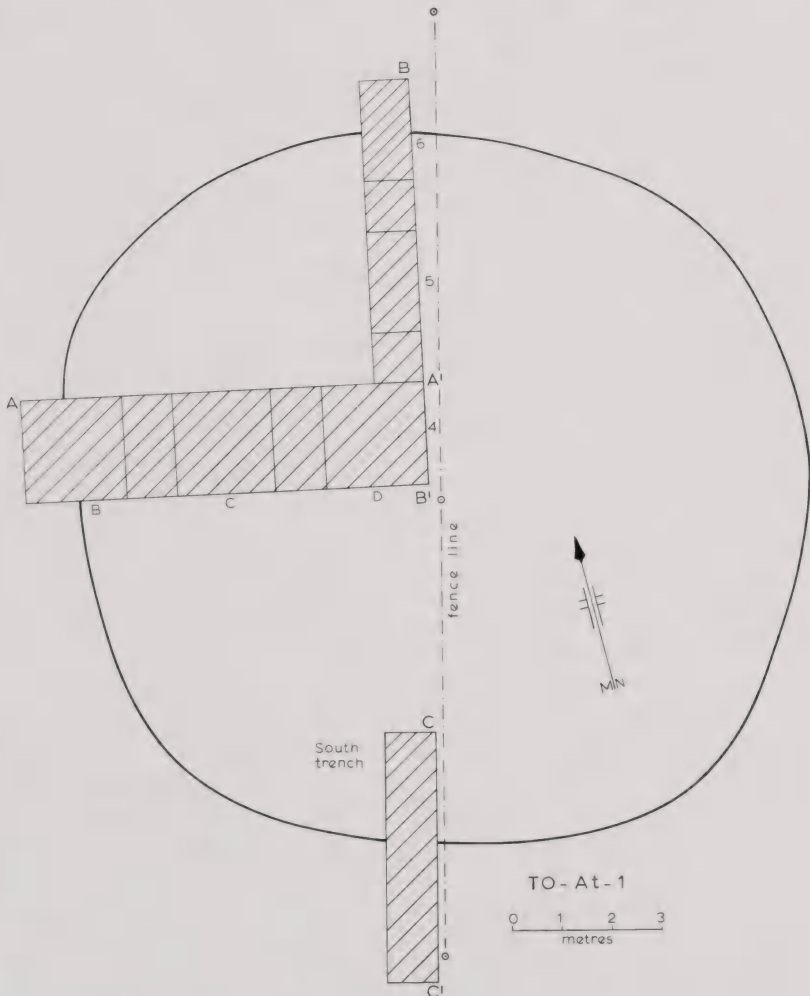

FIG. 4.—Plan of To-At-1, showing area excavated.

Layer 1.—Mixed soil and sand very similar to layer 3. Burial pits dug from the surface of the mound were filled with similar material.

Two sections illustrating this sequence are presented in Fig. 5. Other sections in the central part of the mound showed more burial pits, and less of the major sequence of layers.

In square D-6, separate layers merged in an undifferentiated garden soil. There was no trace of a ditch surrounding the mound. In square B-4, however, a ditch was encountered. As this ditch could not be stratigraphically related to the mound structure owing to ploughing and merging of layers, the south trench was excavated to check the presence of a ditch there.

A ditch was also encountered in this south trench, and here it could be demonstrated that the ditch was almost certainly more recent than layers 4 and 5. It appears that the mound was initially constructed with spoil won from the surrounding ditch, which has since been filled, and its surface ploughed in such a way that its original relationship to the mound has been obscured. The posthole-like features in the fill of the ditch in the south trench are probably recent planting holes.

OCCUPATION SEQUENCE

1. A number of holes, resembling postholes, had been dug on the site. They penetrated the subsoil and were filled with material indistinguishable from layer 5. These holes were initially identified as postholes, but the excavated area was too small for any pattern to be identifiable. As there was no associated midden or artifactual material, the possibility that they were yam planting holes has to be kept in mind.

2. A more definitely domestic occupation succeeded. Further postholes had been dug. These were filled with the black midden material of layer 4, which accumulated on the surface of layer 5. This occupation appears to have been mainly a cooking one, with one large firepit uncovered in square B-4 and baulk, and a smaller one in square D-5. The presumed postholes probably represent a house structure whose overall form cannot be reconstructed because of the limited area excavated. The thinness of layer 4 suggests an occupation of relatively short duration.

3. After the build-up of layer 4 ceased, the first burials were made in the site. These antedated the construction of the mound itself. Pits were dug from the existing ground surface (the surface of layer 4), the bodies placed in them and partially covered with white sand, and the pits filled in. These burials were not all contemporary, but followed one another over a period of time. As a result of the repeated digging and filling of graves and the bringing of white sand to the site to cover burials, layer 3, a mixed soil and sand layer, accumulated on top of the midden layer 4. During this period, at least one house was built on the site and possibly several successive houses. Again, these structures are represented by postholes, which did not normally penetrate the subsoil, but were visible on the surface of layer 4, and in the sections. A house may have been present before the first

Layer 1.—Mixed soil and sand very similar to layer 3. Burial pits dug from the surface of the mound were filled with similar material.

Two sections illustrating this sequence are presented in Fig. 5. Other sections in the central part of the mound showed more burial pits, and less of the major sequence of layers.

In square D-6, separate layers merged in an undifferentiated garden soil. There was no trace of a ditch surrounding the mound. In square B-4, however, a ditch was encountered. As this ditch could not be stratigraphically related to the mound structure owing to ploughing and merging of layers, the south trench was excavated to check the presence of a ditch there.

A ditch was also encountered in this south trench, and here it could be demonstrated that the ditch was almost certainly more recent than layers 4 and 5. It appears that the mound was initially constructed with spoil won from the surrounding ditch, which has since been filled, and its surface ploughed in such a way that its original relationship to the mound has been obscured. The posthole-like features in the fill of the ditch in the south trench are probably recent planting holes.

OCCUPATION SEQUENCE

1. A number of holes, resembling postholes, had been dug on the site. They penetrated the subsoil and were filled with material indistinguishable from layer 5. These holes were initially identified as postholes, but the excavated area was too small for any pattern to be identifiable. As there was no associated midden or artifactual material, the possibility that they were yam planting holes has to be kept in mind.

2. A more definitely domestic occupation succeeded. Further postholes had been dug. These were filled with the black midden material of layer 4, which accumulated on the surface of layer 5. This occupation appears to have been mainly a cooking one, with one large firepit uncovered in square B-4 and baulk, and a smaller one in square D-5. The presumed postholes probably represent a house structure whose overall form cannot be reconstructed because of the limited area excavated. The thinness of layer 4 suggests an occupation of relatively short duration.

3. After the build-up of layer 4 ceased, the first burials were made in the site. These antedated the construction of the mound itself. Pits were dug from the existing ground surface (the surface of layer 4), the bodies placed in them and partially covered with white sand, and the pits filled in. These burials were not all contemporary, but followed one another over a period of time. As a result of the repeated digging and filling of graves and the bringing of white sand to the site to cover burials, layer 3, a mixed soil and sand layer, accumulated on top of the midden layer 4. During this period, at least one house was built on the site and possibly several successive houses. Again, these structures are represented by postholes, which did not normally penetrate the subsoil, but were visible on the surface of layer 4, and in the sections. A house may have been present before the first

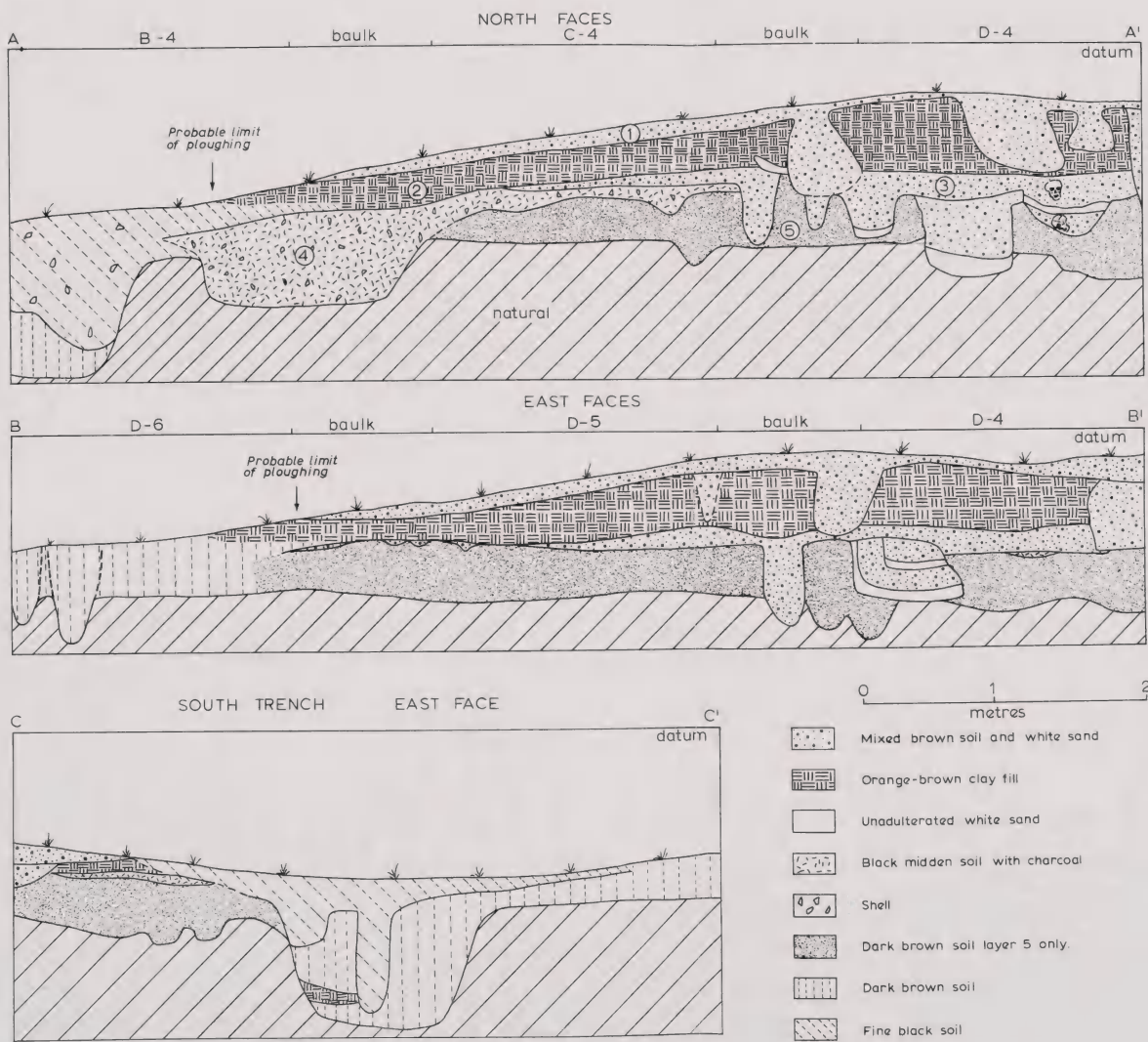

FIG. 5—Principal sections, To-At-1.

interments took place, in which case they would probably have been in the floor of the house. The postholes may also represent a special structure or structures built over the burials.

4. The final phase of use of the site related to the construction and use of the mound for further burials. A low mound was constructed with spoil obtained from a circular ditch partly surrounding the mound, but open to the north. The mound appears to have been built exactly over the centre of the previous burial area. The surface of the mound was then used intensively for burials. On the surface, a mixed layer of sand and soil very similar to layer 3 built up. A few postholes, filled with layer 1 material, located on the surface of the mound, probably relate to a protective structure erected over the burials rather than to a dwelling house.

FEATURES

The only features encountered in this site were the burial pits themselves, the trench surrounding the mound, the postholes of various periods, and the two firepits. There were no other pits. Postholes ranged up to about 60 cm deep and from 20 to 40 cm in diameter. It is possible that some, particularly the earliest and those on the perimeter of the site, are yam holes. The larger firepit was 150 cm in diameter and about 60 cm deep. The smaller was about 70 cm in diameter and correspondingly shallower. Neither contained large concentrations of coral oven stones, but both did contain more charcoal than the remainder of layer 4.

The general dimensions and shape of the surrounding ditch are visible in the sections (Fig. 5). The extent of the ditch could not be determined as it was not visible on the surface. The burial pits are described below.

MIDDEN

The midden content of layer 4 appeared fairly simple. A cursory analysis was made on the site, but no samples were brought back to New Zealand. All shell was collected from layer 4 for examination before being discarded. Coral and other oven stones were collected from some squares only. A crude analysis of midden content is given in Tables 1 and 2.

TABLE 1
QUANTITY OF STONE AND SHELL BY WEIGHT IN SOME AREAS OF
LAYER 4, TO-AT-1.

	B-4	large firepit	Baulk B/C-4
stone	5 lbs	5½ lbs	6 lbs
shell	1 lb	1 lb	2 lbs

TABLE 2
ANALYSIS OF SHELL BY NUMBER IN LAYER 4, TO-AT-1

	B-4	C-4	B/C-4	large firepit	D-5	small firepit
<i>Gafrarium gibbosum</i>	74	925	710	175	150	3
<i>Anadara sp.</i>	1	1	5	1	—	2
<i>Pinctada sp.</i>	40	22	30	9	x*	3
<i>Turbo sp.**</i>	—	3	—	—	—	1
Other	3	13	5	2	—	—

* Present in minute quantities.

** Represented only by opercula.

Coral oven stones were predominant, but a number of unworked pieces of volcanic rock were also found. Samples of this were retained.

ARTIFACTS

Artifactual finds from this site were extremely limited. No pottery was found in association with layer 4. It is possible that a very occasional sherd may have been missed because of the workmen's inexperience. However, all the workmen were familiar with Poulsen's excavations and alert to the possibility of finding pottery. Only two sherds were found in the site, one in the fill of the ditch in B-4, and one in the fill of the ditch in the south trench. Both were plain, very worn, body sherds. An adze fragment, too small for its shape to be inferred, was also found in the ditch in the south trench.

These items could be eroded from the fill of the mound or from the surrounding fields. It seems certain that though layer 4 was a cooking occupation, no pottery was associated with it. Layer 4 may represent a fairly transient occupation or the cooking of a few meals at an agricultural rather than a dwelling site, in which case the absence of pottery would be understandable.

BURIALS

Thirty-eight separate interments, comprising some forty-six individuals, were encountered in To-At-1. The majority were located in D-4 and the adjoining baulks. Only seven extended into C-4 and D-5. Many burials were completely excavated, but some extended beyond the limits of the excavation. Because of the large number of burials in a small space, many had been disturbed and sometimes bones that had been disturbed were reburied in a fresh grave along with the individual for whom it was intended. Condition of the bones varied greatly.

It was not possible to relate every burial to every other in a chronological sequence. However, they could be divided into a number of groups, and the groups arranged in order, from oldest to most recent, as follows:

Group A, prior to the construction of the mound—

subgroup 1: (oldest) 34, then 30 and 29.

subgroup 2: 27, 28, 24, 23, 22, 21, 20 (27 and 28 are contemporary, 23 is more recent than 22).

subgroup 3: 16, 17, 18, 19.

subgroup 4: 10, 11, 12, 13, 14 (12 is more recent than 10 and 11).

Group B, from the surface of the mound—

subgroup 5: 8, 9, 36, 37.

subgroup 6: 2, 3, 5, 7, 32, 33, 35.

subgroup 7: 1, 4, 6, 31, 25, 26.

There was some variety in burial pits. They were mostly oval or rectangular pits; one (29) which contained disarticulated adult bones and two disarticulated child skeletons (Fig. 6) was almost circular. The deepest was about 80 cm deep, while some were hardly pits at all, merely shallow

For cultural reasons, these images have been removed.
Please contact Auckland Museum for more information.

FIG. 6—Disarticulated remains, burial 29, To-At-1.

scooped depressions. The majority of relatively undisturbed adults were in pits about 50 cm deep, with immature individuals in shallower pits, only about 30 cm deep. Many young children were unceremoniously interred in minimal pits, although burials 4 and 26, which included adult remains, were also very near the surface and had suffered accordingly.

Most of the burial pits were straight sided, but one or two had noticeably undercut sides. There did not appear to be any chronological significance in this. One of the earliest and one of the latest pits had this feature. None of the pits was sharply rectangular, all having rounded corners, and rounded junctions between base and sides. The deepest pits were the earliest in both group A and group B. Later burials in each group were shallower, probably because of the increasing likelihood of disturbing existing burials.

There were several instances of multiple burial. Most interesting is burial 29, which consisted of three disarticulated skeletons at least, one adult and two children, buried as three separate bundles in one pit (Fig. 6). As this is one of the first burials on the site, it cannot be due to disturbance on this site. The remains would appear to have been transferred from some other place and carefully reinterred here.

Another definite instance of multiple burial was burial 1 in which two young children were buried one on top of the other in a single pit. Burials 27 and 28 were in a single pit, but it was not clear whether 28, a fragmentary child's skeleton, was the reinterred remains of an earlier burial disturbed by 27.

Other instances of burials assigned one number, but including remains of more than one individual, were almost certainly due to prehistoric disturbance and reinterment. These included burials 4, 10, 13 and 21. Burials that had obviously been disturbed during use of the site and were incomplete or badly fragmented when excavated included 8, 11, 15, 17, 18, 20, 22 and 23, 25, 32, 36 and 37.

An additional problem was disturbance of the excavation by nocturnal visitors, presumably from neighbouring townships. Burials 6, 19 and 34 were disturbed in this way. Finally, mixing and loss after excavation resulted in the non-availability of 15 and 24 (both infants) and part of 14 for specialist study.

Age and sex of individuals from this site are discussed in the following report. Suffice it to say that the population structure appears to be unusual for this site, with a high child mortality rate. All the evidence suggests that a sufficient sample was obtained from this mound, and there is no reason to believe that the unexcavated portion would contain a significantly different proportion of mature individuals.

Ten burials were so disturbed, or had never been articulated, that their position and orientation could not be determined. These were 29, 4, 8, 10, 12, 23, 24, 25, 32 and 33. The last two were only partly exposed by excavation and appeared to have been disturbed by postholes dug from the surface of the mound.

Two further burials whose position could not be satisfactorily determined were burial 20, of which only the edge was encountered, and burial 21B. Both were apparently oriented with head to the east.

Orientation was assessed as the approximate alignment of the body in the direction of the head, and varied between NNE and SE with the exception of burial 37, an infant oriented with head to the south, which was also exceptional in being the only "crouched burial". Other orientations were as follows: NNW three; N twelve, NNE five; NE three; ENE nil; E four; ESE two; SE two. There appeared to be no significant variations between subgroups, examples from each being fairly widely distributed within this range. Nor was there any noticeable difference between orientations of mature and immature individuals.

The majority of burials, both adult and immature, were in a supine position. The remainder were on their sides. None was in a prone position. With the exception of burial 37, all were extended. Of those whose position could be determined, there were seventeen supine (Fig. 7), three right sides, five left sides, one left turned slightly towards prone (Fig. 8), and one left turned slightly towards supine. The supine position was used



For cultural reasons, this image has been removed.
Please contact Auckland Museum for more information.

FIG. 7—Portion of burial 14, To-At-1.



For cultural reasons, this image has been removed.
Please contact Auckland Museum for more information.

FIG. 8—Burial 12, To-At-1.

throughout the sequence; representatives of every subgroup were in this position. With the exception of burial 12, however, an individual from subgroup 4 buried on its left side turned towards a prone position, all burials that were not supine belonged to the more recent Group B. There appeared to be no difference between the positions of adults and children.

There was considerable variety in arm position. Some had both arms parallel to the sides, some had crossed or folded arms and some had hands doubled up to the chin. There were other variations, one arm folded across the body and the other extended, or doubled up to the chin. There was less variety in the disposition of the legs, however, which were either straight and parallel, slightly bent at the knee, or crossed at the ankle.

There were no grave goods. The amount of white sand in the grave fill varied considerably. The pit of burial 6 was almost completely full of sand, while others had only an inch or two, or none at all. In some cases a dark stain was noted in the sand. This is thought to have been due to the disintegration of black tapa cloth wrapping, noted by early visitors to Tonga (Wilson 1799) and still used in Tongan burials. There appeared to be little correlation between age at death and the presence of quantities of sand and dark staining. Some children, particularly, were buried with quantities of sand, in which a strong dark stain was noticeable.

DATING

Samples of bone from burial 34 were submitted for radiocarbon dating of collagen. Although the sample of bone submitted was thought to be more than adequate, insufficient collagen was obtained for reliable dating. The laboratory quoted a date of less than 1200 years old (a reading of almost modern activity taken to three standard deviations) (GaK-1203, Kigoshi pers. comm.).

SUMMARY

The primary use of this site throughout most of its history was as a burial place. Burials were made both from the surface of the mound, and from the previously existing ground surface prior to the construction of the mound. Apart from the construction of the mound itself, there was apparently no change in burial practice, and the positioning of the mound over the centre of the previous burial area suggests continuity of use.

The use of the site for burial was preceded by a cooking occupation, probably transient, but of sufficient importance for the importation of at least some volcanic cooking stones. An earlier use of the site, of uncertain nature, is evidenced by holes, resembling postholes, penetrating the subsoil.

EXCAVATIONS AT TO-AT-2

The second mound selected for excavation is significantly larger than To-At-1 (Fig. 9) and differed from it in being encircled by a visible ditch. In terms of size, this site was well within the range described by McKern



FIG. 9—General view, To-At-2.

for *faitoka* (chiefs' burial places) and it was thought that it might prove to contain the coral slab vault supposedly characteristic of *faitoka*.

A long trench, one metre wide, was laid out through the entire mound, and excavated in several sections, three sections on the north side first, followed by three on the south side. Eventually, intervening baulks were removed so that a complete section through the mound was obtained. At either end of the main trench an extension was opened up in an attempt to locate postholes or other features on the outer edge of the encircling ditch.

A second trench, also one metre wide, was set out at right angles to the first. Only the outer portions of this trench were excavated, and were designated the east and west trenches. They were excavated to obtain further information about the size and alignment of the submound discovered in excavating the principal trench, rather than to obtain further data on burials.

A grid of one-metre squares was imposed on the site, numbered along a north-south axis and an east-west axis. Each excavated square was numbered according to the intersection of grid lines at its northeast corner, and all burials were plotted in relation to such points (Fig. 10).

The two trenches provided cross-sections through the mound (Fig. 11). Both were excavated completely to underlying subsoil.

Because of the occurrence of potsherds in the area immediately surrounding the mound, and the lack of a recognisable occupation layer beneath the mound itself, two test pits were excavated in areas most productive of surface sherds. These were named test pits A and B (Fig. 10). Test pit A was found to be unrewarding and was not extended. Test pit B, however, revealed a pit which was partly filled with shell midden. Accordingly, excavations in this area were extended towards the mound itself, and eventually to a point where the relationship between the numerous pits in the area and the ditch encircling the mound could be investigated. The whole area, which was diagonal to the main site grid, was labelled Excavation B.

STRATIGRAPHY OF THE MOUND

In the area of the mound itself six main layers could be determined. From the bottom upwards, they were (Figs. 11-12):

Layer 6.—A thick layer of dark brown soil, which filled a large shallow pit and at least one posthole beneath the mound itself. In the main trench, two subdivisions of this layer could be identified, a harder browner zone at the base, and a softer blacker zone nearer the surface. This layer contained most of the potsherds found in the mound, and very occasional shell and fragments of turtle bone.

Layer 5.—A thin layer of mixed white sand and soil.

Layer 4.—A mixed fill of dark brown soil and more orange clay derived from excavation in the immediate vicinity.

Layer 3.—A mixed layer of white sand, and material similar to layer 4.

Layer 2.—A fill consisting largely of hard orange subsoil won from the surrounding ditch and forming the upper layer of the mound.

Layer 1.—Mixed clay, soil, and white sand.

While the stratigraphy was very clear in the centre of the mound, the same problems of merging layers on the fringes of the site were encountered as had been experienced at To-At-1. As all layers were composed of similar materials, developed on the same subsoil, and in some cases redeposited, it was very difficult to separate them where they were not separated by the unmistakable scatter of white sand on a surface that had been used for burials. This problem arose particularly in describing the fill of the two ditches. The inner ditch clearly antedated the construction of the mound in its final form, but its own fill could not be clearly related to layer 4. As is often the case with such ditches, the fill appeared to be derived partly from layers 6 and 4, and partly from soil outside the submound area. The sections presented are slightly simplified, in that all the soil lenses of the major layers and ditch fills are not shown.

The two trenches provided cross-sections through the mound (Fig. 11). Both were excavated completely to underlying subsoil.

Because of the occurrence of potsherds in the area immediately surrounding the mound, and the lack of a recognisable occupation layer beneath the mound itself, two test pits were excavated in areas most productive of surface sherds. These were named test pits A and B (Fig. 10). Test pit A was found to be unrewarding and was not extended. Test pit B, however, revealed a pit which was partly filled with shell midden. Accordingly, excavations in this area were extended towards the mound itself, and eventually to a point where the relationship between the numerous pits in the area and the ditch encircling the mound could be investigated. The whole area, which was diagonal to the main site grid, was labelled Excavation B.

STRATIGRAPHY OF THE MOUND

In the area of the mound itself six main layers could be determined. From the bottom upwards, they were (Figs. 11-12):

Layer 6.—A thick layer of dark brown soil, which filled a large shallow pit and at least one posthole beneath the mound itself. In the main trench, two subdivisions of this layer could be identified, a harder browner zone at the base, and a softer blacker zone nearer the surface. This layer contained most of the potsherds found in the mound, and very occasional shell and fragments of turtle bone.

Layer 5.—A thin layer of mixed white sand and soil.

Layer 4.—A mixed fill of dark brown soil and more orange clay derived from excavation in the immediate vicinity.

Layer 3.—A mixed layer of white sand, and material similar to layer 4.

Layer 2.—A fill consisting largely of hard orange subsoil won from the surrounding ditch and forming the upper layer of the mound.

Layer 1.—Mixed clay, soil, and white sand.

While the stratigraphy was very clear in the centre of the mound, the same problems of merging layers on the fringes of the site were encountered as had been experienced at To-At-1. As all layers were composed of similar materials, developed on the same subsoil, and in some cases redeposited, it was very difficult to separate them where they were not separated by the unmistakable scatter of white sand on a surface that had been used for burials. This problem arose particularly in describing the fill of the two ditches. The inner ditch clearly antedated the construction of the mound in its final form, but its own fill could not be clearly related to layer 4. As is often the case with such ditches, the fill appeared to be derived partly from layers 6 and 4, and partly from soil outside the submound area. The sections presented are slightly simplified, in that all the soil lenses of the major layers and ditch fills are not shown.

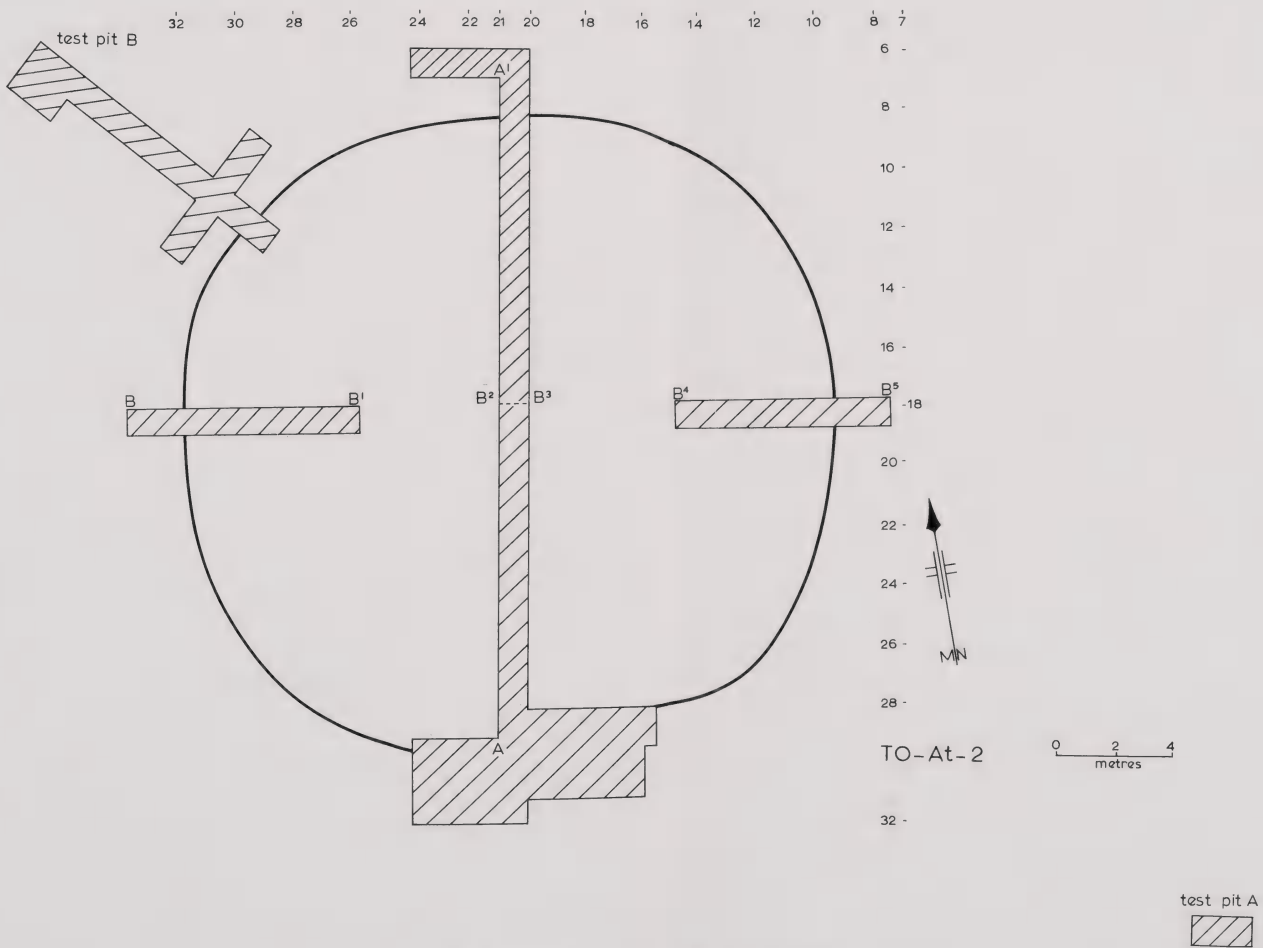
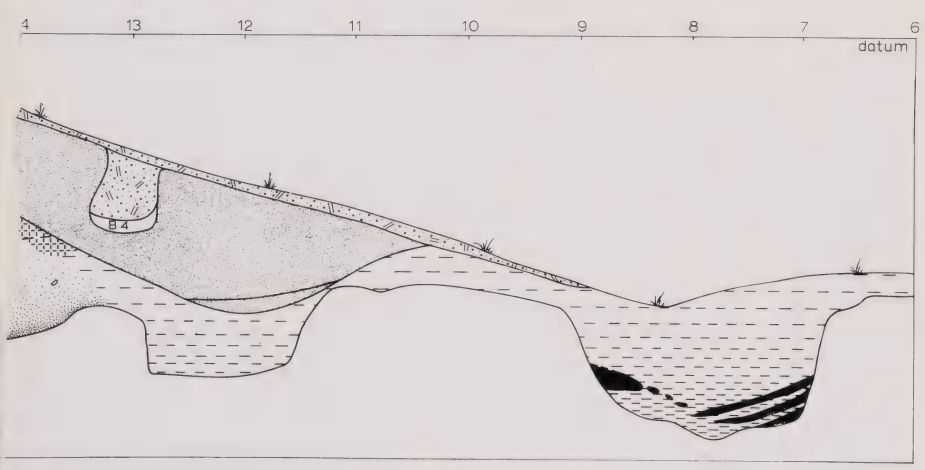
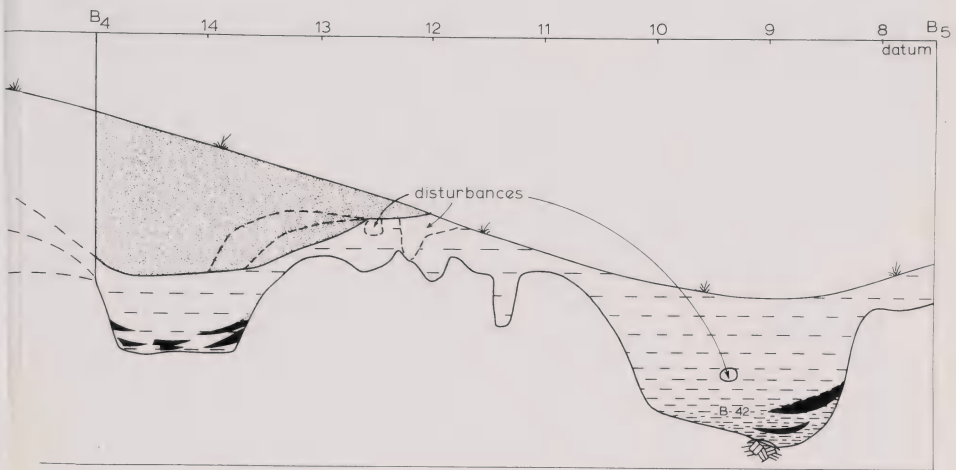
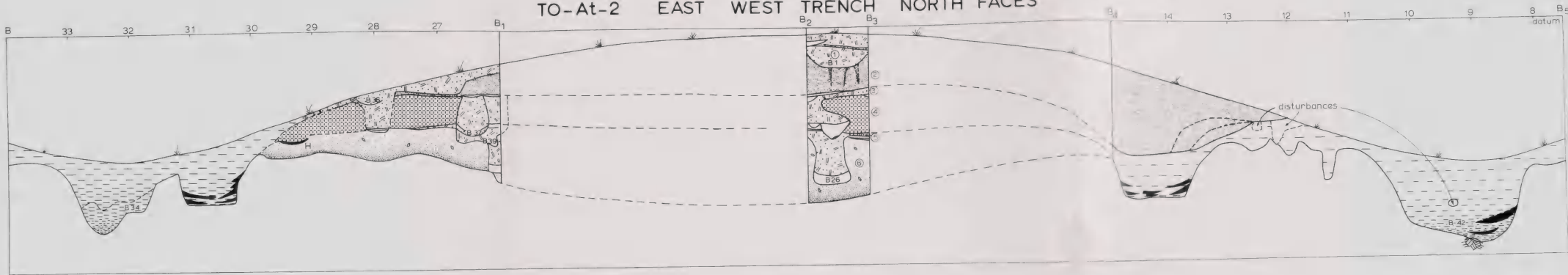

FIG. 10—Plan of To-At-2, showing excavated areas.



TO-At-2 EAST WEST TRENCH NORTH FACES



0 1 2 3 metres

TO-At-2 MAIN TRENCH WEST FACE

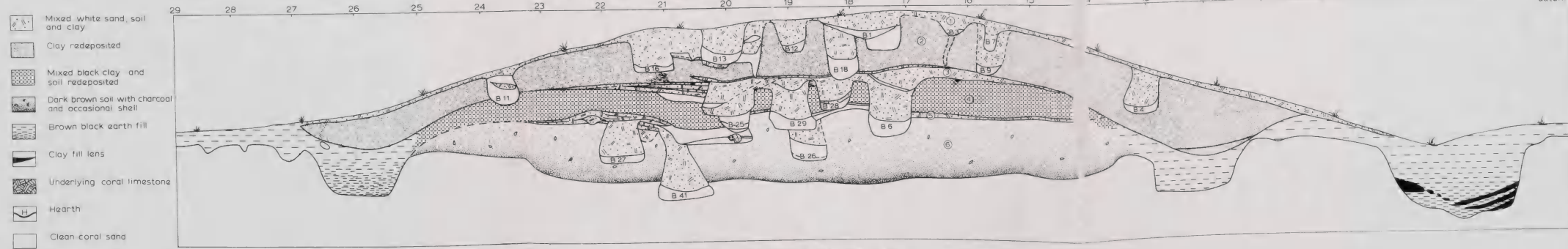

FIG. 11—Principal sections, To-At-2.



FIG. 12—Main trench, To-At-2, looking north, showing west face, part of Period 1 pit (in right foreground) and surrounding ditches of Periods 3 and 4.

SEQUENCE OF MOUND CONSTRUCTION AND USE

1. A large shallow pit, and at least one posthole, indicate an initial occupation of the site not concerned with burial. Little of this was revealed in the excavated area. These features are filled with layer 6.

2. The features of the initial use of the site were infilled, possibly deliberately, and the surface raised again to a level the same as, or slightly higher than the surrounding ground surface. The first burials were made from this surface. These burials were placed in pits, at least one of which had markedly undercut sides, partly covered with white sand, and filled.

3. A small mound approximately the same size at To-At-1, but more oval in shape, was formed from spoil won from a surrounding ditch, and new burials made from its surface. These burials were also in pits, though some were much shallower than those of the earlier phase. Sufficient time elapsed for the surrounding ditch to become largely filled in.

4. The mound was enlarged by excavating a second and larger surrounding ditch outside the earlier one, and heaping the spoil from it on top

of the existing submound. Further burials were made from the surface of the enlarged mound.

5. A few further burials in the sides of the mound and in the fill of the surrounding ditch may have been added hastily and unceremoniously at a later time.

FEATURES

Few features were encountered in the area of the mound itself. Pits revealed in Excavation B are discussed separately below.

The only features definitely belonging to Period 1 were the large shallow pit, and one posthole. Edges of this pit were found at two points in the main trench, and in the west trench. They are shown on Fig. 13, together with a possible reconstruction of the outline of the pit. One

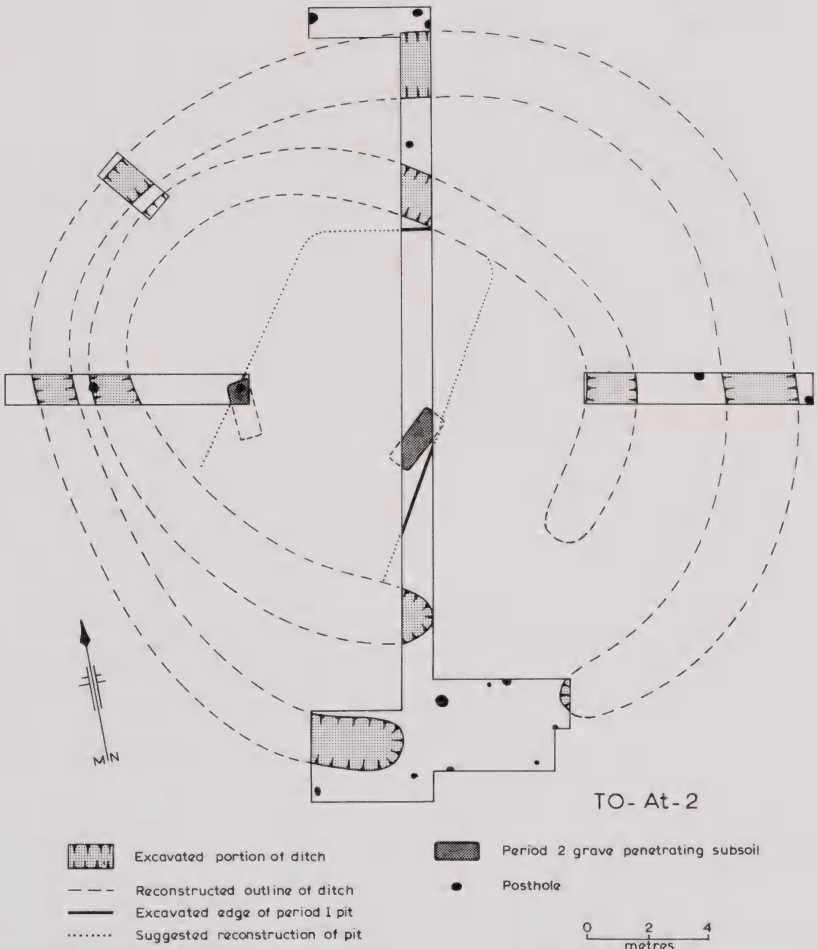

FIG. 13— Plan of features penetrating the subsoil, To-At-2, and suggested reconstruction of the Period 1 pit and the ditches of Periods 3 and 4.

posthole was found in the edge of this pit, in the west trench. It is clearly sealed by a Period 2 burial which also penetrated the subsoil at this point. The posthole may actually be associated with the pit.

No interpretation of this structure can be advanced. It does not appear to be a natural feature, however. Its floor is perfectly smooth in contrast to the uneven and disturbed surface of the subsoil elsewhere in the site, and its edges, although low, are clearly defined (Fig. 12). With so limited a portion uncovered, its actual size and shape can only be guessed, but it would appear to be at least 10 x 7 metres, although only about 20 cm deep.

The presence of the posthole suggests that a structure could have been associated with the pit. Either an agricultural or a dwelling function would appear to be indicated, probably the former.

One other posthole almost certainly belongs to Period 1. It is the single posthole between the inner and outer ditches in the northern part of the main trench (Fig. 13).

Period 2 is represented only by burial pits which do not appear to differ from those of To-At-1, or from later periods on this site.

Periods 3 and 4 are represented by the submound and mound, with their surrounding ditches, burial pits, and postholes.

The excavated portions of the surrounding ditches and their reconstructed forms are shown in Fig. 13. Both ditches are incomplete and open towards the southeast.

Several problems arose in the identification of postholes. All over the site (except in the floor of the Period 1 pit) were numerous minor disturbances of the subsoil, often of irregular shape, and usually shallow. These could be caused by gardening, root disturbance or burrowing animals of various sizes. Quite substantial disturbances of the soil in the east trench were due to ant colonies. Most disturbances were not accepted as postholes. There appeared to be a fairly clear division between regular features penetrating at least 30 cm into the subsoil, often considerably more, and features which are shallower. The former were tentatively identified as postholes, although the possibility of yam holes must be kept in mind. It was not possible to relate these presumed postholes stratigraphically to either phase of mound construction, although it is probable that if they relate to the mound at all, it is to Period 4. The position of the presumed postholes as shown on Fig. 13 suggests that there could have been a surrounding fence on either the inner or outer side of the ditch in Period 4. There is little evidence in the excavated area for a fence surrounding the submound.

ASSOCIATED MATERIAL

Several potsherds were found in the mound and in the extensions at either end of the main trench. A single adze fragment was found in the fill of the outer ditch in the southern extension. Occasional fragments of shell and non-human bone were found in layer 6 and in the fill of the

ditches. There was very little midden or artifactual material in the site altogether, and no occupation layer comparable to layer 4 at To-At-1 was located.

Twenty-five sherds were found in layer 6 beneath the mound. All were undecorated and very weathered. Two were rim sherds. One sherd was found in layer 2, four in the fill of the Period 4 ditch, and twenty-two in the undifferentiated garden soil in the northern and southern extensions of the main trench. A further five sherds from this site are not precisely localised. There were no rim sherds other than the two from layer 6, and all sherds are plain and well weathered. They appear to have been lying around near the site prior to its use for burial, but no occupation layer has been identified as their source.

The adze fragment from the fill of the outer ditch is of interest as it is the butt end of a small adze of triangular section, probably with apex to front. It is flaked, but the median ridge is ground, suggesting apex to front. This type of adze is rare in Tonga. Its age is difficult to determine. Its context in the site is late, in the fill of the outer ditch, but like sherds from similar contexts it may be derived from the surrounding garden soil and be older than the site.

BURIALS

The burials in this site were not as close together nor as disturbed as those from To-At-1. Even here, however, some burials had disturbed earlier ones, resulting in intrusive bones in burials 20, 21 and 30. Burial 1, in the centre top of the mound, consisted of a number of successive interments on one spot, resulting in considerable mixture of bones.

The narrower trench excavated meant that very few complete burials were exposed. In the centre of the mound, numerous burials were merely touched upon at the sides of the trenches. Burials were sufficiently numerous and close to one another to render extensions on either side of the trench at the centre of the mound impracticable. An exception was made in the case of the particularly well preserved and relatively isolated burial 4, however.

Towards the close of the excavation, some difficulty was experienced with crumbling of the sides of the trench, owing to the quantity of loose sand present in the faces. Many of the unassigned bones from this site are the result of erosion of the faces revealing other burials.

Unfortunately, the early burials in the centre of the mound were not well excavated, because of the danger that the walls of the excavation would collapse. This is probably the reason for the presence of intrusive bones in these burials. Under the more controlled conditions which existed during excavation of upper layers, this problem did not arise.

Burials 30 to 36, located in the west trench, were all rather shallow and consequently in poor condition. A further perplexing feature of this site was the discovery of several badly crushed burials in the fill of the outer

ditch. Although these were not in good condition, they appeared to have been placed in the ditch in a position of articulation, rather than to have eroded out of the fill of the mound. They lacked recognisable grave pits, and white sand covering.

Since excavation, all bones from burials 1B (an infant) and 12 (an adult) and the skull of the important burial 4 have been lost. While such losses may seem inexcusable, they are at least partly due to souvenir hunting, rather than to negligence on the part of the excavator.

Most burials were in pits very similar to those at To-At-1. The range in pit size and shape, and in quantity of white sand, is clearly shown in Fig. 11. Pits which do not appear in the illustrated sections did not differ from those illustrated.

Because the burials in this site were more spread out, they cannot be placed in sequence as satisfactorily as those from To-At-1. They can, however, be assigned to the major periods of use of the site as follows:

Period 2: 26, 27, 39, 40, 41.

Period 3: 5, 6, 20, 21, 22, 23, 25, 28, 29, 37, 38.

Period 4: 1, 2, 3, 4, 7, 8, 10, 11, 12, 13, 14, 15, 16, 17, 18, 19, 30, 31, 32, 33, 35, 36.

Period 5: 24, 34, 42.

Although several burials in this site contained bones from more than one individual, there were only two instances where two individuals appeared to have been buried deliberately at the same time in the same grave. Burial 13 consisted of parts of three individuals. Number 13C was an earlier burial whose grave pit had been almost entirely destroyed by the later interment of 13 and 13A, two adults buried at the same time face to face (Fig. 14). The other certain double burial was burial 40, located in the west trench, where two adults had been buried one on top of the other in a deep but narrow grave. This burial was also interesting in that fragments of what appear to be tapa cloth, now hardened to a form like papier mâché, were found in association with 40A, the lower of the two individuals. Only the end of this burial lay within the area of the excavation (Fig. 13) and unfortunately little skeletal material was removed for study.

Of the remaining complex burials numbers 1 and 13C involved reuse of the same location on top of the mound, 24 consisted of fragmentary remains in the fill of the outer ditch, and 30 was excavated as a bundle of assorted bones, the only example of clearly disarticulated remains in the main portion of the mound. Two of the Period 3 burials in the middle of the mound, 21 and 22, involved superimposed but not contemporary burials in the same place.

Orientation of skeletons from this mound is best described by Periods. Period 3 and 4 burials show a fairly consistent pattern of orientation with greater diversity in Periods 2 and 5.

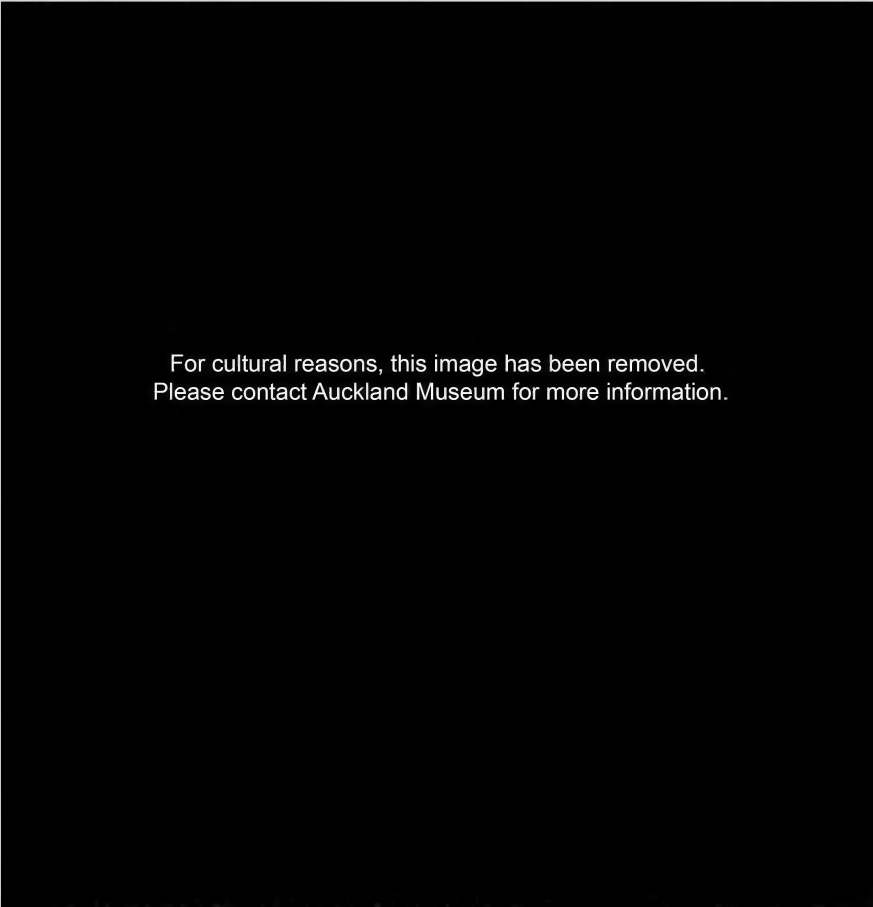

For cultural reasons, this image has been removed.
Please contact Auckland Museum for more information.

FIG. 14—Period 4 burials, To-At-2. Burial 12 (in foreground) and 13 (at rear).

The five Period 2 burials whose orientation could be determined were widely distributed as follows: WSW one; N two; ENE two. These are the earliest burials on the site and antedate the construction of the mound.

With the building of the submound, orientation became more consistent: SE eight; E three; NNE one; N one. The last two were both in the west trench. The pattern of orientation for Period 3 therefore can be interpreted either as predominantly SE-E or as feet towards the centre of the mound.

Among Period 4 burials, orientation became even more consistent: ENE two; E seven; ESE three; SE twelve; SSE one. It is worth noting that both Period 3 and Period 4 burials tend to be oriented towards the gap in the surrounding ditches.

The final burials of Period 5 are again more varied: NW one; N one; SSE one.

There seemed to be no significant variation in orientation between adults and children, nor any significant correlation between orientation

and position, except that there appeared to be a tendency for those oriented towards the north to be lying on their left sides, thus facing east.

At this site, as at To-At-1, the supine position was most common, except in Period 2. Only one of the Period 2 burials was in the supine position, with two left side and two right side. Of Period 3 burials, however, eight were supine (of which three were slightly tilted to the right). There were three right side and one left side. Period 4 burials included a number of immature individuals. Position, where it could be determined, was as follows: supine fourteen (three immature); probably supine four (two immature); supine tilted to the right one (immature); right six (two immature); probably right one (adolescent); left two. The possible totals for Period 4 burials then are supine nineteen, right side seven, left two. In Period 5 burials there were two supine and one left.

In this site also there was some diversity of arm positioning. Most burials in a lateral position have both hands doubled up to the chin, and in one case (burial 40) it was clear that tapa cloth and/or mats had been wound tightly round the body with arms inside. Among supine burials, the arms were usually extended, but there are instances of folded arms, and of one hand under the chin. Only one supine burial (from Period 2, burial 41) had both hands under the chin.

Legs were normally extended, sometimes slightly bent at the knee, with one case of crossed ankles.

The majority of burials in this site were in pits and covered with white sand. Several infants or young children were in very shallow pits, but most pits were of reasonable depth.

There were thirteen exceptional burials which lacked white sand or recognisable pit. Four burials without pits were encountered in the main trench, burials 10 and 19 (adults) and burials 3 and 9 (children). Six more of the exceptional cases were in the west trench, where a number of shallow and apparently unceremonious burials were found. Of these, burials 30 and 36 were in shallow pits with little or no trace of white sand, while numbers 31, 32 and 33 had little trace of a pit and no white sand. These five are all from Period 4. Burial 39, a Period 2 burial, was in a clearly defined pit, but lacked all trace of white sand. Finally, the three late burials in the fill of the outer trench, numbers 24, 34 and 42, lacked recognisable pits and white sand covering.

The dark stain, thought to be indicative of black tapa cloth wrapping, was observed in a fairly small number of burials in this site. Only one of the numerous Period 4 burials, 1C, was noted as having this characteristic. On the other hand, four Period 3 burials, 20, 22B, 23 and 29, had pronounced black stains. Of the Period 2 burials, 41 had a noticeable black stain and, as noted above, 40A had what appeared to be fragments of tapa present in the sand. All the burials in this site that had black staining were adults, in contrast to To-At-1 where staining was also present on several immature individuals.

There were no durable grave goods.

The population from this site is described in the following report. Age and sex distribution appear to be more normal than at To-At-1.

DATING

Two samples of bone from this site were submitted for collagen C14 dating. A left femur and right humerus from burial 41, a Period 2 burial and probably the earliest burial on the site, gave a determination of 770 ± 200 years before 1950 (GaK-1204), and a left tibia and fibula from burial 10 (Period 4) gave a date of 390 ± 110 years before 1950 (GaK-1205). Collagen recovered from these bones was barely sufficient, hence the relatively large error.

The dates set the mound fairly clearly in the prehistoric period, and indicate that its use was spread over a considerable time. Allowing for one standard deviation, burial 41 falls between the 10th and 14th centuries, and burial 10 between the 15th and 17th centuries. Allowing two standard deviations, burial 41 falls between the 8th and 16th centuries, and burial 10 between the 14th and 18th centuries. If the true age of burial 10 falls close to the upper limit of 1780 A.D. it is possible that contact with Europeans was affecting the mortality rate during the later stages of mound use, though unlikely that miscegenation would have taken place to any extent. The chances are, however, that the mound is truly prehistoric.

SUMMARY

The history of the burial ground may be summarised as follows.

First use of the site is little known, but included a large shallow pit, and at least one posthole. Virtually no midden material is associated with this occupation, suggesting an agricultural rather than a residential use of the site. The first burials were made from the surface of a soil which filled the earliest features. Although there was no mound at this time, the burials were in pits, sometimes with undercut sides, and covered with white sand. One of the early burials shows dark staining of the sand, and one contains fragments of what may be tapa cloth. A date on collagen from burial 41 indicates a clearly prehistoric date probably around the beginning of the second millenium A.D. It should be noted that almost all potsherds found in the mound are stratigraphically earlier than burial 41, and by their very eroded appearance would seem to have been in a garden area before becoming sealed under the mound.

The next event on the site was the building of the submound, an oval mound surrounded by a ditch with a gap to the southeast. The mound was formed from spoil won from the surrounding ditch. From the surface of this submound, burials were made in similar pits, but there is no evidence from the excavations of any associated structure on the surface. Evidently some time elapsed after the building of the submound, for the surrounding ditch was almost entirely filled, and a considerable layer of mixed sand

and soil derived from burials built up on the surface. Burials of this period were again in pits with white sand, and a dark stain in the sand is fairly common.

The final stage was the construction of the mound as it is now with spoil from an outer ditch, and further burials in the surface. A collagen C14 date for this period suggests a late prehistoric age. Burials of this period were also in pits with white sand covering, but the dark stain is very rare. Probably even later are several burials in the surroundings of the mound.

ADDITIONAL EXCAVATIONS AT TO-AT-2

Excavations in the area surrounding the mound were made initially in an attempt to locate the source of potsherds found on the surface of the field, and at the base of the mound.

Test pit A was set out on what appeared to be a very slightly raised area southeast of the mound. A series of soil zones was found in this excavation. The surface of the subsoil was not flat, but riddled with small disturbances which may be due to gardening or root action. There were apparently no man-made features. Above the subsoil was a brown soil divided in two by a darker zone in the middle. The total profile was about 30 cm deep. A relatively high concentration of sherds was found in this area, 14 sherds in two square metres. This is relatively low, however, by comparison with sites excavated nearby at Pea and Ha'ateiho. Test pit A can only be characterised as a garden soil containing potsherds.

A series of pits was encountered in Excavation B. These were not all contemporary, but intercutting, suggesting that the area had been used for pits over a period of time. Only the most recent, or the deepest of these pits, survived in recognisable form. In 14.5 m², ten pits of recognisable plan were uncovered and there must have been at least four others of which no edges remain in the excavated areas. The pits are of two main forms, circular, and rounded rectangular.

The best preserved (and probably most recent) of the circular pits have pronouncedly undercut sides (Figs. 15-17). The rectangular pits are less well preserved. Two of them, however, seem to have been undercut on one side, but not on the other. Pit G is undercut on the east side, and pit H on the west side. (A number of burial pits also display this asymmetric section.)

The floor plans of all the pits are shown in Fig. 15. A, B and C are circular pits with undercut sides of varying diameter and depth. D appears to have been a circular pit of similar type which has been largely cut away. E may be either circular or rounded rectangular and lacks undercut sides. F is probably also an earlier circular pit largely destroyed by later pits.

G and H are definitely rectangular pits, I is probably a rectangular pit, and J is a smaller oval pit with undercut sides.

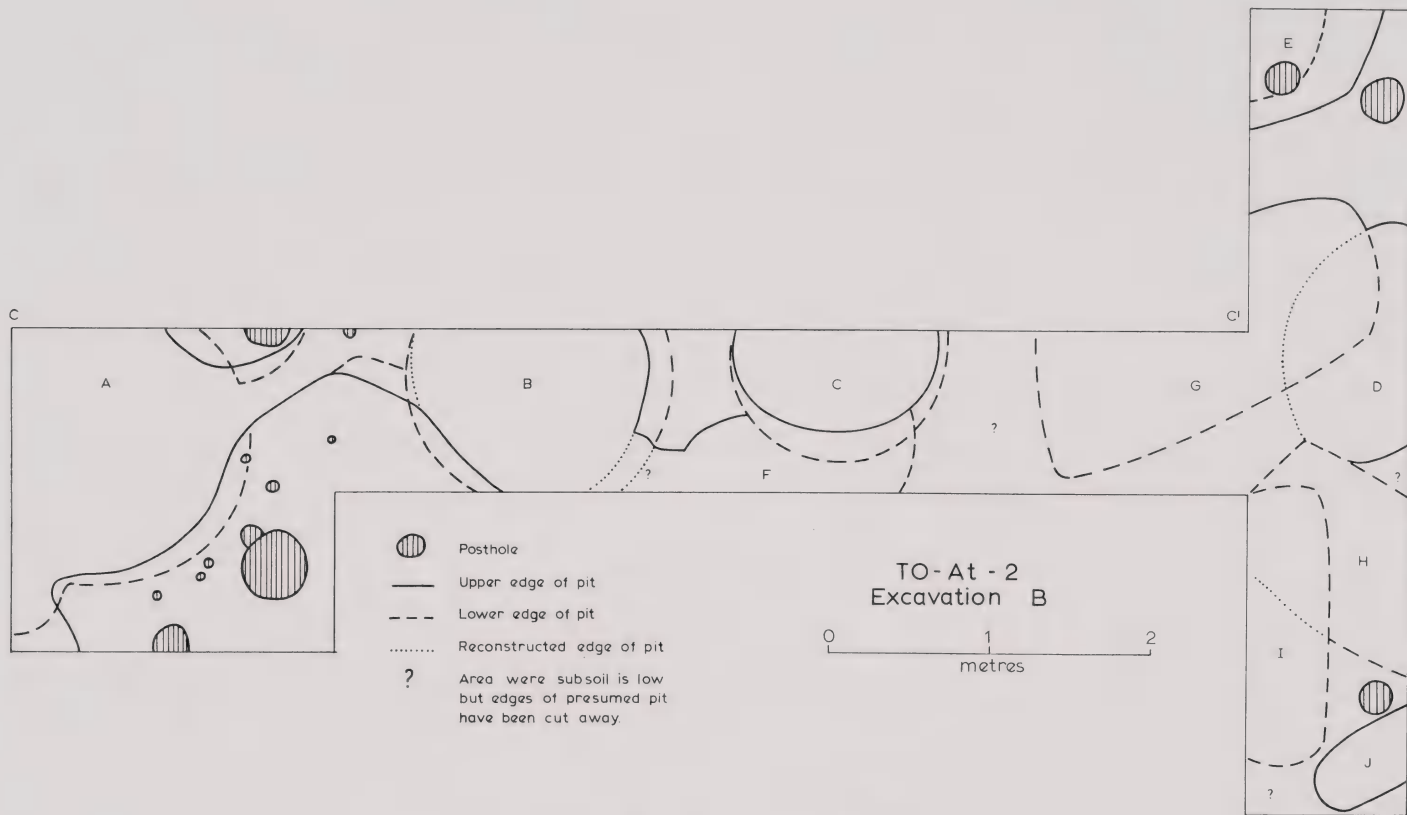

FIG. 15—Plan of pits in Excavation B, To-At-2.

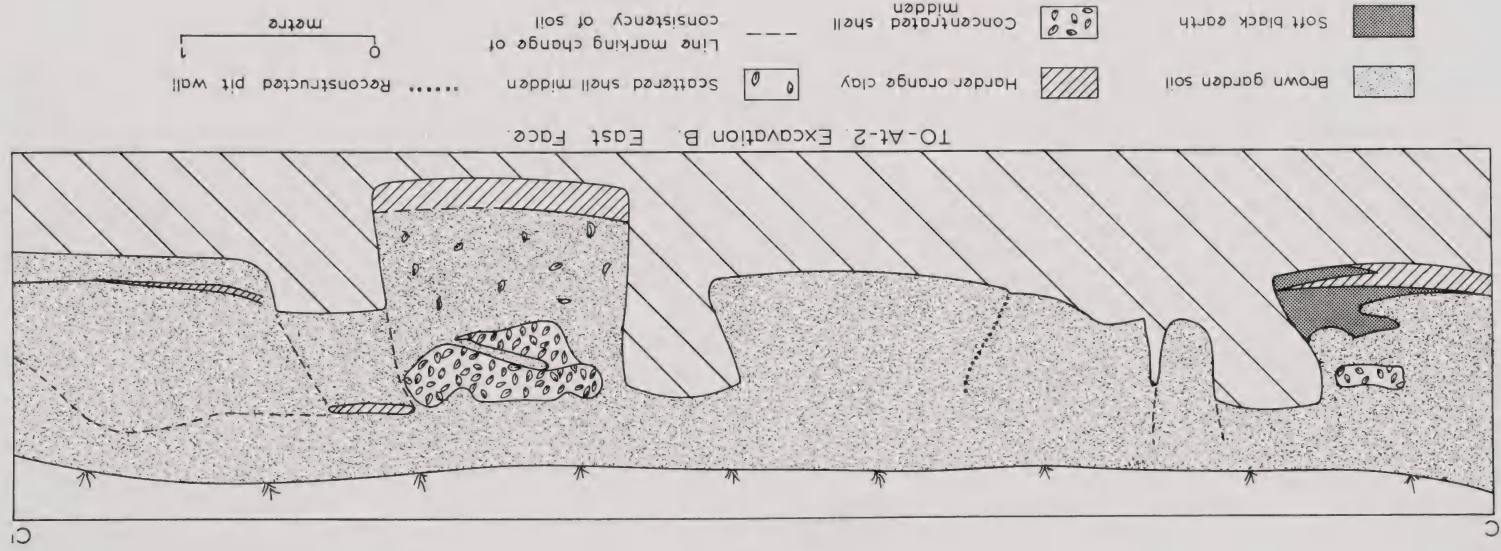

FIG. 16—Section through pits A, B, C, and G, east face of Excavation B.

For cultural reasons, this image has been removed.
Please contact Auckland Museum for more information.

FIG. 17—Excavation B, To-At-2, showing pits G, C, B and A (from foreground to rear).

Circular pits range in diameter from about 1.2 to 1.8 m, and in depth from 1 to 1.5 m below present ground surface, although the hypothetical pit D would be only 80 cm deep as is E. An interesting feature of pit A is a tunnel or funnel leading from it to another pit of which we uncovered only the edge. The workmen said that this was a feature of pits still in use for ripening bananas.

The dimensions of pit G appear to have been approximately 2 x .5 m. Pit H is of similar size, but whereas G attained a depth of well over 1 m, H was only 80 cm deep. J is the same depth as H, but I is nearer 1 m in depth.

Most of the pits were filled with an undifferentiated brown soil, very similar to the topsoil in the surrounding fields. A and C, however, which seem to be among the most recent of the pits, appear to have filled partly naturally with typical clay lenses near the base and sides, and partly to have been used as dumps for shell midden. By contrast, the earlier pits appear to have been filled deliberately, rather than left open to fill naturally.

The shell midden from these pits consisted largely of *Gafrarium gibbosum* shells. There are occasional other shells, and some burnt coral rock, together with a few fragments of turtle bone and human bone.

Sixteen weathered undecorated body sherds were found in Excavation B. In addition, there were three small pieces of volcanic rock, two of stone suitable for cooking, and one apparently suitable for adze making. Three *Anadara* shells have perforations which would enable them to be used as net sinkers. The potsherds are mostly from the brown soil and, like the sherds in layer 6 under the mound, may have been lying in the area for a long time. The other material comes mainly from the fill of pits A and C.

Extension of Excavation B to the ditch surrounding the mound showed clearly that the Period 4 ditch was stratigraphically later than those pits (D, H, ?) nearest the mound.

On stratigraphic grounds, no more accurate context can be assigned to the pits. The pits themselves appear to relate to a single and continuous phase of activity, possibly several seasons' use of one plantation area, and it is probable that not only D and H, but all pits, antedate Period 4 of the mound. It is unlikely though not impossible that intensive non-funerary activity would be practised in the immediate vicinity of a burial ground. The most attractive context for these pits would be in association with Period 1 of the mound, but although there are some slight inferential grounds for this assignation, stratigraphic evidence to support it is lacking.

It is probable that the pits have some kind of agricultural function. Storage of vegetable crops in pits to ripen or ferment them is widespread in Polynesia, and similar circular pits, sometimes with undercut sides, have been found in excavations in Eastern Polynesia (Suggs 1961, p. 63; Green et al. 1967, pp. 136-137). Pits have also been found in other excavations in Tonga (Birks pers. comm.). The pits in this site have been described in some detail, because their prehistoric context is fairly certain, and their forms are fairly well preserved. It is to be hoped that careful study of historical descriptions, and enquiries about modern agricultural practices in Tonga will produce satisfactory interpretations of these and similar pits.

DISCUSSION

On the basis of these excavations, some conclusions can be advanced concerning burial mounds and burial practices.

The presence of white sand on the surface of a mound, even in small quantities, appears to be a fairly certain indication of a funerary function. On the other hand, the size range reflected in Tonga College mounds (excepting the three at the entrance) does not appear to reflect a difference in function, or in the status of those using the mound. Although To-At-2 is certainly large enough to qualify as a *faitoka* in terms of McKern's description, there is no evidence that it was used by persons of higher rank

than those of To-At-1. The size difference between the two mounds appears to be due to the fact that one is a "three-storeyed" burial mound, while the other has only two storeys.

Excavations in both mounds revealed a continuity in burial practice, apparently over a considerable period of time. In both sites, the characteristic burial pit and partial white sand fill antedate the actual construction of a mound, and the form of the pit and positioning of the individual are similar throughout the use of both mounds. There is no sign in either site of the modern custom of heaping up a mound of white sand over the grave, and no evidence of post-European use in the form of bottle glass decoration.

Evidence is not clear either for the presence of houses on the surfaces of the mounds, or for surrounding fences. This is largely because of the limited area excavated in both sites. At To-At-1 several postholes were found which could relate to one or more house structures on top of the mound. Such houses would have been built after the initial use of the mound's surface for burial, as some Group B burials were disturbed by them. Only one posthole was found in the surface of To-At-2, but this was probably because of the smaller area sampled. This posthole was 60 cm deep and contained charcoal. There is some evidence that fences could have surrounded the mounds, but it is not definite that the postholes are contemporary with use of the mounds.

Although both mounds have similar histories of construction and use, there are minor differences between the two. One consistent difference relates to orientation. At To-At-1, north was the most favoured orientation, with a marked preference for east and southeast at To-At-2. This difference apparently relates to the opening in the surrounding ditch, but this correlation may be purely coincidental, and the difference may merely be a chance preference of two different groups using the mounds.

Another difference is the more intensive use of To-At-1 at both periods of its history. The greater intensity of use tends to correlate with a higher number of immature interments. This may well be due to more selective use of To-At-2 during Periods 2 and 3, than during Period 4, and of To-At-2 at all periods compared with To-At-1, rather than to changes in population structure and mortality rate. On present evidence, it is impossible to say.

A third difference between the two sites is the apparently more restricted use of black tapa at To-At-2, and its more liberal use at To-At-1, which may also be due to slightly differing practices or status of two separate groups. If the dark staining does indicate decayed organic matter, a respectable antiquity for the use of black tapa or mats is indicated.

The age of To-At-1 in relation to To-At-2 has not been determined. Both reflect similar burial practices, and To-At-1 probably falls largely within the time span indicated for To-At-2 by its C14 dates.

McKern's limited excavations in Tonga included four burial sites. One, a site on Pangaimotu, appears to have been similar to the sites described here, although it had subsequently been used for non-funerary purposes (McKern 1929, pp. 104-106). McKern regarded this site as a forgotten *faitoka*, even though it did not contain a coral vault. Of the others, one, with surface stone work, contained an unusual coral vault and limited skeletal remains (pp. 108-109), while two traditional *langi* on Tongatapu lacked vaults, and contained in one case no human remains at all (confirming a tradition respecting its use for the burial of a wooden doll), and in the other only one complete individual and a few disturbed bones (pp. 113-114). McKern noted the constant use of sand in these sites, the presence in the Pangaimotu site of a dark stain in the sand, the general use of the supine position, and varying orientations.

Two burial mounds at least were destroyed during the construction of the airport at Fua'amotu, Tongatapu, in 1940. According to Mr. H. O. Wright, who was engaged in the airport construction, burials in these mounds were covered with white sand, and placed with their feet towards the centre. Children were placed in spaces around the periphery of the mounds (B. I. McFadgen, pers. comm.).

One of Poulsen's sites, To-2, contained a number of skeletons in the upper levels, indicating use of the site as a burial mound. He also encountered an isolated individual buried at To-1 (Poulsen pers. comm.).

McKern's Pangaimotu site, the Fua'amotu mounds, and Poulsen's To-2, all appear to have been similar sites to the two at 'Atele. They indicate widespread use of these sites, lacking coral vaults, but with white sand, and sometimes dark staining of the sand. While orientation within a single mound may be fairly consistent, however, there appears to have been fairly wide variation from site to site.

McKern believed that the coral vault was a fairly late feature of Tongan burial practice, and that earlier burials, even of chiefs, lacked this feature. He thus tended to classify all sizable mounds as *faitoka*, those without vaults being possibly older. It seems likely, however, that the mounds described in this report were burial places of common people, and certainly not burial places of important chiefs.

Considerable evidence is already available about Tongan burial customs and there is undoubtedly a rich field of ethnohistorical material on Tonga awaiting investigation, which will prove of value to both prehistorian and anthropologist. Only most obvious published sources have been consulted to provide a few guidelines for interpreting burial mounds described here.

McKern devoted a considerable part of his field study to a description of burial mounds. He classified all mounds (partly on formal grounds, but largely by the supposed function assigned to them by informants) into *esi* (chiefly resting places), *siaheulupe* (pigeon snaring mounds), and three categories of burial mounds, with a residual category of mounds of unknown use. Burial places were divided into *tanuanga* (commoners' burial

places), *faitoka* (chiefly burial places) and *langi* (burial places of members of the Tui Tonga family) (McKern 1929, pp. 30-31). He realised that this was a functional classification rather than a formal one, but believed that there was a standard recognisable form for each category.

Of *tanuanga* he wrote:

The *tanuanga* may be described as a small mound of earth or sand, similar in shape and size to European grave mounds. It needs no special consideration as it has no important bearing on Tongan archaeological problems (1929, p. 31).

Of *faitoka*:

The *faitoka* is normally a comparatively large mound of earth and sand, in shape a truncated cone with moderately sloping sides, containing from one to several stone vaults. The term *faitoka* includes not only the mound, which was more specifically called *foifaitoka*, but also a definite area surrounding the mound where a chieftain's important retainers and distant relatives were buried.

Langi were generally larger and more elaborate, often with dressed stone, and most known *langi* were described individually by McKern. Both *langi* and *faitoka* were believed to contain stone vaults of a similar type. *Faitoka*, of which McKern apparently observed a number, varied considerably in size, but he considered that a *faitoka* of average size would be about 8 feet high with a base diameter of 75 feet (McKern 1929, p. 32), in other words, about the same size as To-At-2.

Present-day informants do not distinguish clearly between the three categories, and it is no longer possible to apply McKern's classification in the field, using traditional evidence.

Various early visitors to Tonga described burial mounds of important personages, usually referred to as *faitoka*, and several are illustrated. The word *langi* is not mentioned in early accounts. Cook described a large "Affi-a-too-ca or burying ground belonging to the King", although he subsequently used *morai* interchangeably for *faitoka*, and implied that such places were used for religious purposes as well as for burial. He may have been influenced by Omai's interpretation of Tongan custom. The *faitoka* he described consisted of three mounds surrounded by a stone wall. Each mound was surmounted by a house, and Cook was told that the dead were buried in a stone vault beneath the floor of the house (Cook 1967, 1:138). He did not observe a funeral. A "fyatocka" or "fiatooka, or morai", with four small houses on its surface, was drawn by J. Webber, and another larger mound with a house on its surface, in another of Webber's illustrations, may also be a *faitoka* (Cook 1784, Atlas pl. 21-22).

The missionaries left in Tonga by the "Duff" in 1797 also described several "fiatooka". They first visited the "fiatooka" belonging to Mumu'i, which they described as a beautiful, solitary place surrounded by trees, containing two god houses, one apparently concerned with male pursuits such as war, and one with female affairs, notably bark cloth manufacture. There was no mention of burial (Wilson 1799, p. 235). A later description, however, referred to a mound some 7 feet high and 120 yards in circumference, with a house on top, beneath the middle of which was a coral vault (p. 241). Here they saw a funeral and described quantities of black tapa being lowered into the grave.

Two *faitoka* each containing three tombs were seen at Togamalolo, forming part of a complex together with a large house and an open green space (p. 252); and the burial mounds at Mu'a, now usually called *langi*, were described as "fiatooka" and said to be badly overgrown and in disrepair at that time (Wilson pp. 252, 283-285, and print).

Mariner also observed funerals. He defined "fytoea" as:

A burying place including the grave, the mount in which it is sunk, and a sort of shed over it. The grave of a chief's family is a vault, lined at the bottom with one large stone, one at each side, and one at the foot and head . . . covered at the top with one large stone (Martin 1827, 1:135).

By the time Dumont D'Urville reached Tonga, contact with Europeans was well established. The illustrations of his first voyage include three views of chiefs' burial mounds, and a plan of some of the sites at Mu'a (Dumont D'Urville 1833, Atlas pl. 80, 86, 95 and 101). At least one of the mounds illustrated is no larger than To-At-2. All have one house on them.

These brief examples from historical descriptions suggest that during the early European period *faitoka* was the widely used term for a burial place, particularly that of a chief. Most, if not all of these chiefs' burial places were said to contain a coral vault, and all had at least one house on them. Webber's drawing with its several small houses perched at precarious angles on the slope of the mound is exceptional.

To-At-2 appears to be within the size range of these *faitoka*, particularly those illustrated by Sainson, the artist with D'Urville. In its lack of a coral vault, however, it falls short of the description of chiefs' mounds, and it seems reasonable to assume that this site, like To-At-1 was probably not a chief's burial place.

Little can be said about the groups using the mounds. Again, historical research may produce evidence about Tongan social structure which would provide a clue as to the identity of the groups likely to be responsible for raising and using mounds of this type. The apparent evidence for continuity of burial practice at each site suggests that each was used by members of one social group who were acquainted with the practices relating to each mound. Some account of the population as represented by skeletal remains in the mounds is given in the following report. A few comments about the appearance of the Tongan people as observed by early visitors to Tonga may be appropriate here.

Most visitors from Tasman on commented on the robust stature of both men and women. Of particular interest, in view of the various evidences of pathology observed in the excavated skeletons, are comments about disease.

Cook noted the presence of venereal diseases, reported by his crew, on his third voyage (1777). He and his crew were convinced that these had not been present at the time of his earlier visits (1773, 1774) and apparently Tongan informants upheld this view. Cook also noted that from the time of his first visit many Tongans had been afflicted with ulcerous

sores similar to those resulting from venereal disease, but said by the Tongans to have been present before European contact, and to be due to different causes (Cook 1967, 1:170-171).

Mariner, on the other hand, believed that venereal diseases were not present in Tonga during the first decade of the 19th century, though he commented on various ulcerous afflictions (Martin 1827, appendix 2) as did the first missionaries (Wilson 1799, p. 264). Mariner also commented on the skill of the Tongans in setting fractures (Martin, appendix 2).

There is abundant evidence for the existence of ulcerous infections of a kind which could be responsible for the observed pathology of a number of bones excavated. The more precise diagnosis of this disease, however, is dependent on whether syphilis was present in pre-European times. Historical evidence suggests that it was not.

The position of the 'Atele mounds in relation to other sites is of interest. As stated above, the majority of visible mounds in the college grounds are burial mounds, and there is a conspicuous lack of large mounds of unknown function such as abound in some areas of Tongatapu. No occupation site of any depth or concentration has been located at 'Atele, although such sites abound at Pea and Ha'ateiho.

The absence of occupation sites suggests that the 'Atele area has never been used on a large scale for settlement, but that it has served as an agricultural area, and for burial of people from neighbouring settlements. Such an explanation would help to account for the conspicuous lack of pottery throughout the area. If pottery was made and used widely throughout the prehistoric period, more would have been found at 'Atele than has so far been located. An alternative explanation would be that pottery was not made or used at 'Atele during the period the burial mounds were in use. In this case the absence of pottery at 'Atele would not necessarily imply an absence of settlement. However, such a view is entirely inconsistent with the results of excavations at Pea by Poulsen, and cannot be seriously entertained at this point.

The other explanation, that 'Atele was not a residential area, opens up interesting possibilities. The nature of sites at 'Atele contrasts markedly with the situation at Pea and Ha'ateiho, and suggests that population has been clustered in these latter areas for a long time. It is widely accepted that settlement in Tonga was not nucleated prior to the civil wars of the protohistoric period. This may well be true on smaller islands. In Tongatapu, however, the evidence from Pea, Ha'ateiho, and 'Atele, suggests a marked and continuous preference for the two former over the latter as a residential area, and a use of 'Atele for non-residential purposes such as cultivation, and burial.

CONCLUSIONS

Investigation of these two small burial mounds has revealed that even very small mounds were used intensively for burial over a long period

of time. Both mounds show successive stages of use for burial, two at To-At-1 and three at To-At-2. In both cases the first stage antedated the construction of the mound, although burial in an extended position in pits with white sand covering was the rule in both sites throughout their use. To-At-2 is larger than To-At-1, not because it is a different kind of site, but because it went through a third stage of use, while To-At-1 had only two.

Both mounds are estimated to contain well over 100 individuals, with To-At-1 probably containing more immature individuals.

Some evidence for initial non-funerary use was encountered at both sites, but neither at these two sites, nor elsewhere in the 'Atele area, was evidence of habitation of any duration noted. There appears to be a strong contrast between 'Atele and neighbouring Pea and Ha'ateiho, suggesting a possible long standing concentration of residence at the latter areas, and a use of 'Atele for burial and agriculture. Numerous pits on the edge to To-At-2, and faint signs of human activity in the early periods of both sites, are assumed to be evidence of cultivation and food storage.

McKern's threefold classification of Tongan burial sites is found to be unsatisfactory, both for present-day use, and in terms of early European descriptions of Tongan burial practices. Such descriptions are largely confined to chiefly burial places, several of which were illustrated, and appeared to differ little from To-At-2, except in size, most being larger. All had houses on the top, and some evidence for surface structures was found in both To-At-1 and To-At-2. The principal differences between To-At-2 and these *faitoka*, or chiefly burial places, is the absence in the former of a coral vault, and perhaps its large number of burials.

There would thus appear to be no universal rule for distinguishing in the field between the larger of the commoners' burial places and the smaller chiefly mounds. The gradation and overlapping of mound size may reflect a gradation and overlapping of status. Burial customs observed for chiefs in the early European period were probably imitated on a lesser scale by all classes of Tongan society at that time. The main elements of these burial customs appear to extend back at least to the beginning of the present millenium.

REFERENCES

COOK, James

1784. *A voyage to the Pacific Ocean performed under the direction of Captains Cook, Clerke and Gore in . . . the "Resolution" and the "Discovery"*. London, Nicol and Cadell.
1967. *The journals of Captain James Cook on his voyages of discovery. III. The voyage of the "Resolution" and "Discovery" 1776-1780*. BEAGLEHOLE, J. C. (ed.). Cambridge University Press, for the Hakluyt Society.

DUMONT D'URVILLE, J. S. C.

1833. *Voyage de la corvette "l'Astrolabe" exécuté par ordre du roi, pendant les années 1826 - 1827 - 1828 - 1829 . . . Histoire du voyage . . . Atlas historique*. Paris, J. Tastu.

EMORY, K. P.

1962. Three-year Polynesian research programme. *N.Z. Arch. Assoc. Newsletter* 5: 96-97.

GOLSON, J.

1957. Report to Tri-institutional Pacific Program on archaeological field work in Tonga and Samoa. Mimeographed, Auckland.

GREEN, R. C., KAYE GREEN, R. A. RAPPAPORT, ANN RAPPAPORT & JANET M. DAVIDSON

1967. Archaeology on the island of Mo'orea, French Polynesia. *Anthrop. Pap. Am. Mus. nat. Hist.* 51(2): 111-230, pl. 17-24.

MCKERN, W. C.

1929. Archaeology of Tonga. *Bull. Bernice P. Bishop Mus.* 60: 1-123. Bayard Dominick Expedition Pub. 15, Honolulu.

MARTIN, J.

1827. *An account of the natives of the Tonga Islands, in the South Pacific Ocean . . . compiled and arranged from the extensive communications of Mr. William Mariner, by John Martin.* 3rd edition. Edinburgh, Constable and Hurst.

POULSEN, J.

1967. A contribution to the prehistory of the Tongan Islands. Unpublished Ph.D. thesis, Australian National University, Canberra.
1968. Archaeological excavations on Tongatapu. In YAWATA, I. & Y. H. SINOTO (editors). *Prehistoric culture in Oceania: symposium presented at the 11th Pacific Science Congress.* Honolulu, Bishop Museum.

SUGGS, R. C.

1961. The archaeology of Nuku Hiva, Marquesas Islands, French Polynesia. *Anthrop. Pap. Am. Mus. nat. Hist.* 49(1): 1-205.

WILSON, J.

1799. *A missionary voyage to the southern Pacific Ocean, performed in the years 1796, 1797, 1798, in the ship "Duff" . . .* London, T. Chapman.